

**S 61 K..S+F/T**

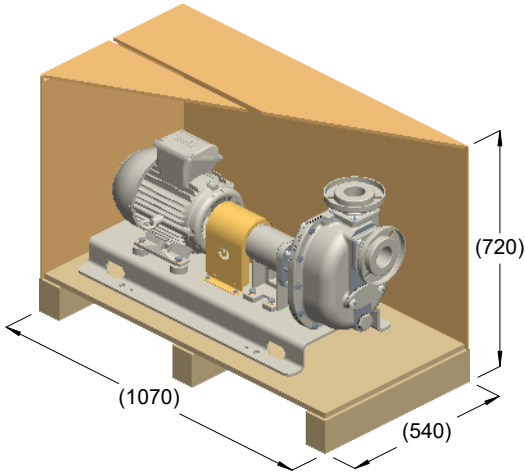

kg = 130  
m<sup>3</sup> = 0.42

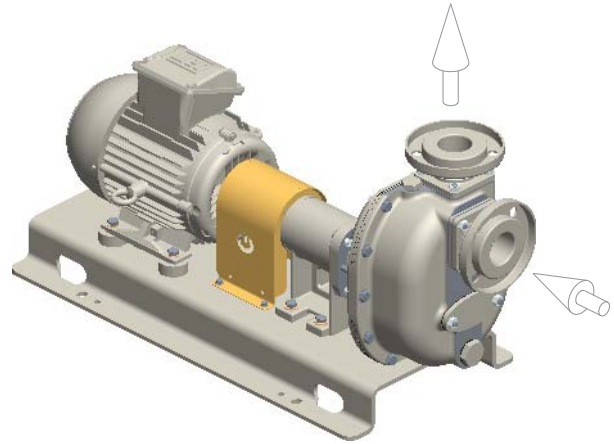

Kg=116

